

PARTS LIST

ITEM PART	DESCRIPTION	QTY	
1	CE-CEL-ROLLER	Rollers	4
2	SK-SKY50HI	Thru-Glass Pull with 2 Gaskets	1
3	CE-CEL-STOPPER	Stopper	2
4		2, 3, and 4mm Allen Wrenches	3
5	CE-CEL-WALLBRKT	Adjustable Wall Brackets	2
6	CE-CEL920	Reversible Door Guide with Insert	1
7	CEL-TRKHLD	Fixed Panel Fittings	2
8		Mounting Anchors	3
9	CEL-SCREWBAG	Mounting Screws	3
10		Levels	2
11		Wrench	1
12		Drill Bit	1
13	SL-CEL-1501	Header Bar	1
14	SL-SKY PVCD 19	Vinyl Door Bulb Seal	1

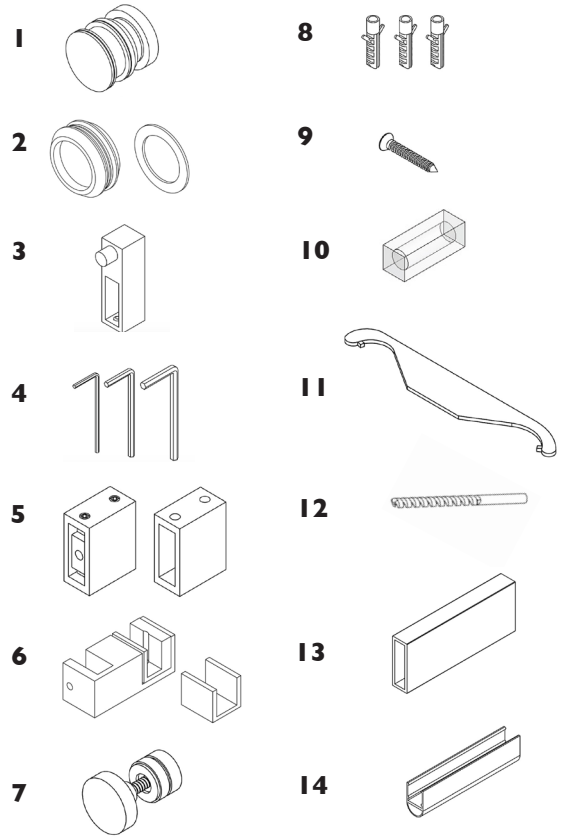

NOTE: Read Instructions thoroughly before installation. Make sure all parts are present. If anything is missing or damaged please contact your service branch.

ATTENTION: Door can't exceed 30" or 88 lbs.

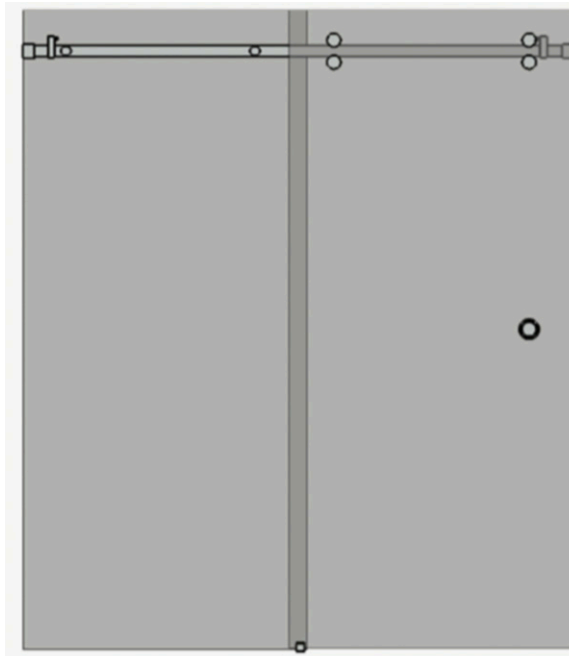

NOTE: Bottom support needed on fixed panel (not included).

STEP 1

Remove rollers from box and remove threaded decorative caps.

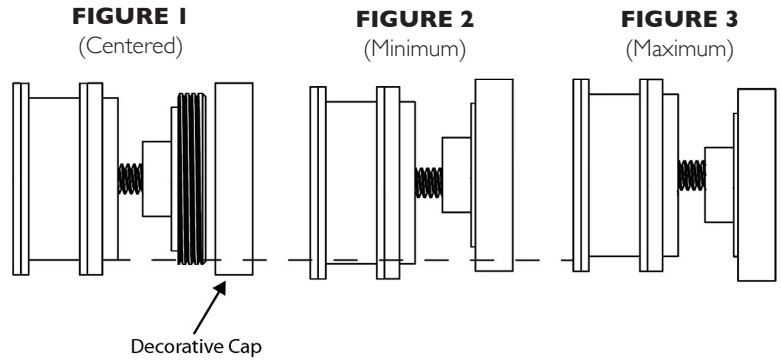

STEP 2

Install top rollers on door glass by removing Allen bolt, interior plate, and gasket. Install top rollers on glass in the centered position (See figure 1). This will make adjustments easier after door is installed. Bottom rollers will be installed after door is hung.

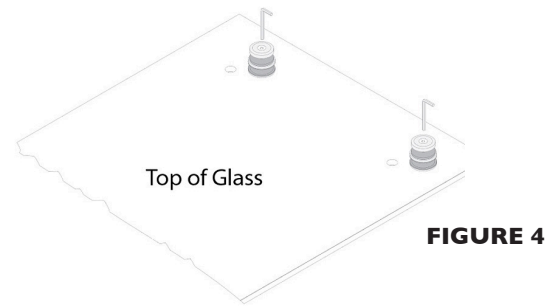

STEP 3

Mark location on your walls for header bar. Header must be installed at a minimum of 1-3/16" from the edge of curb substrate and 3" down from overall unit height.

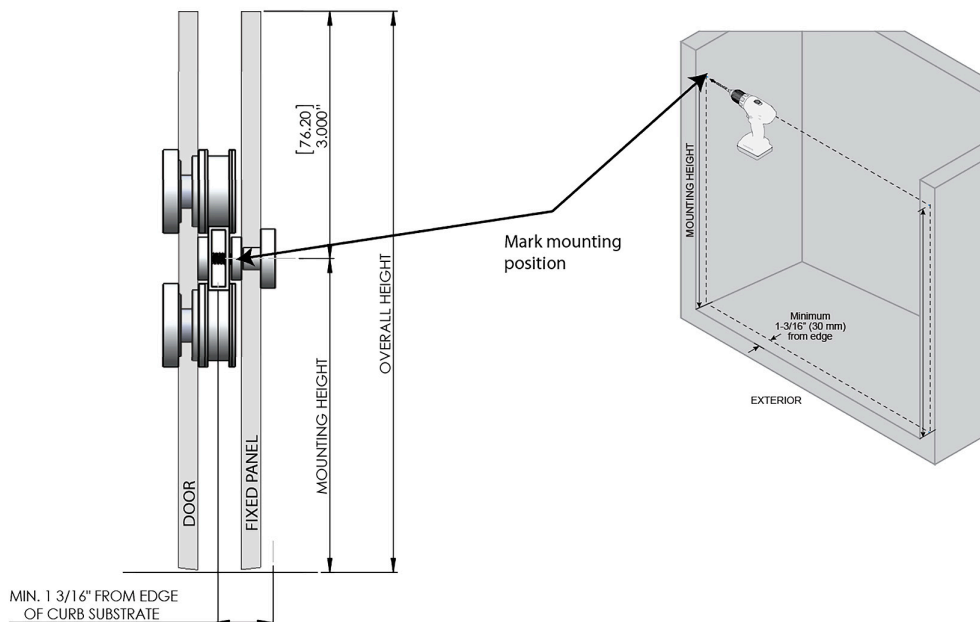

FIGURE 5

STEP 4

Using a 1/4" bit, drill holes for the wall brackets, insert anchors.

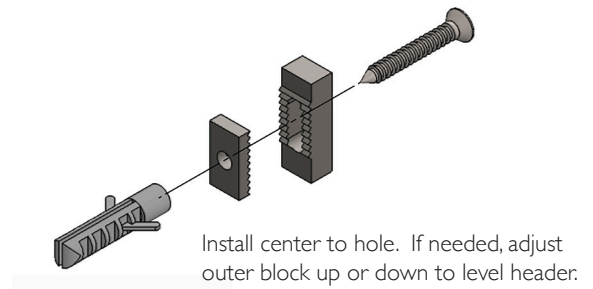

FIGURE 6

STEP 5

Install mounting blocks, smaller block goes to wall. (Install mounting blocks centered to the hole, later if needed you can adjust the header up or down).

STEP 6

Measure opening width where mounting blocks were just installed. Deduct 1" to get header width. Cut header to size. (Header is made from stainless steel, use a special cutting tool).

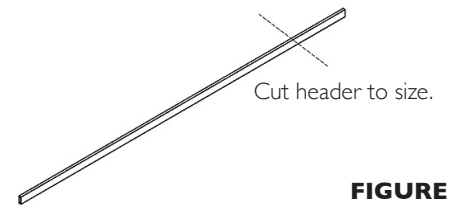

FIGURE 7

STEP 7

Install wall brackets and stoppers on header bar. Ensure that the Allen screws are loosened (to prevent scratching). Then slide stoppers and wall brackets on header, make sure that the bumpers on the stoppers are both facing each other. The Allen screw in the wall bracket that is closest to the edge will be facing the wall. Allen screws on the wall bracket should be facing up.

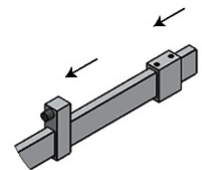

FIGURE 8

STEP 8

Place stick on levels on header bar. Put header bar in place, ensure it's level, then slide wall brackets over the mounting blocks. Tighten set screws to secure.

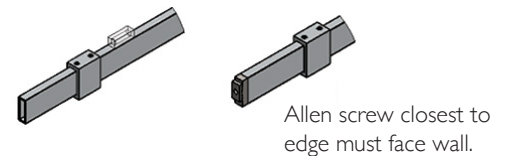

FIGURE 9

STEP 9

Place stationary panel in place (make sure to place a block under glass to account for proper base support and leave a small (1/16") gap at wall). Level and ensure it's plumb. Mark the glass on threshold. Mark the header by aligning the holes in the glass to the center of the header. Remove glass and set aside. NOTE: if using clamps on the panel, mark for those holes at this time. If using channel, cut 1 1/16" shorter than width of panel glass.

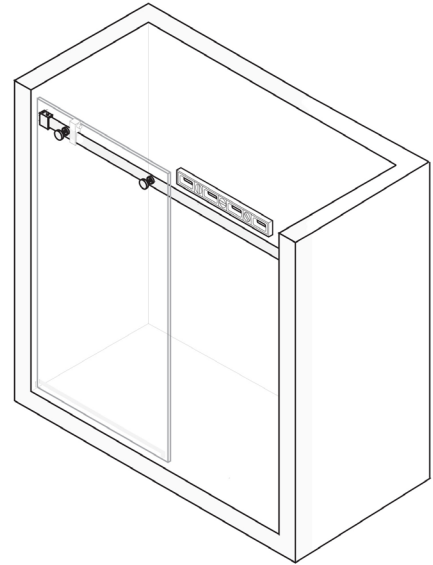

FIGURE 10

STEP 10

Make sure the marks in header are centered then drill (2) holes with supplied drill bit.

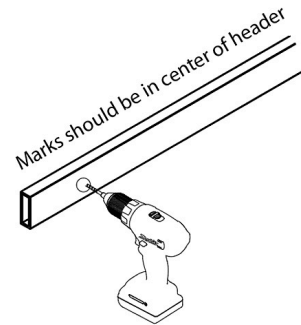

FIGURE 11

STEP 11

Install fixed panel U-Channel or wall clamps. Place stationary panel in place (make sure glass is resting on setting blocks). Attach stationary panel to header bar using two clamps provided (Fixed Panel Fittings). NOTE: All clamps and rollers have threaded decorative covers.

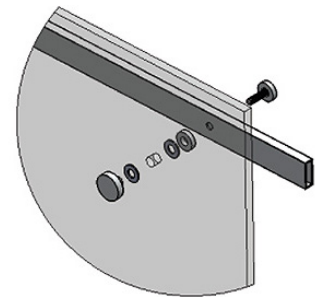

FIGURE 12

STEP 12

Place center guide in place, capping over end of stationary panel. Mark hole for center guide, remove. Drill a 1/4" hole, insert anchor, replace center guide then screw in place.

NOTE: There are two center guide insert options. The narrower (A) of the two is for a standard 3/8" glass option without the optional poly carb sweep. If you are using the optional poly carb sweep use center guide insert (B).

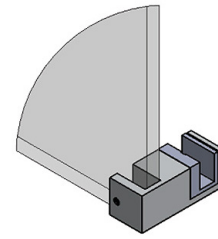

FIGURE 13

STEP 13

Set sliding door in place on header bar. Making sure the glass is also sliding into the center guide.

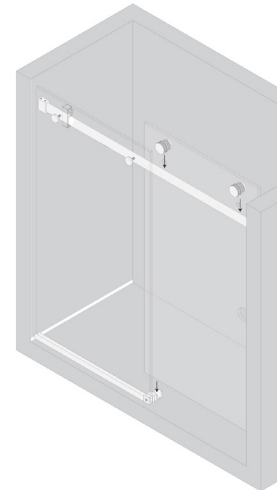

FIGURE 14

STEP 14

Make sure that the top of the door and panel are level with each other. Also make sure the door hits the wall straight. You can adjust the door to at this time if needed.

STEP 15

Install bottom rollers and adjust them up so they are barely touching bottom of header. (See Figure 15)
Install supplied handle. (See Figure 16)

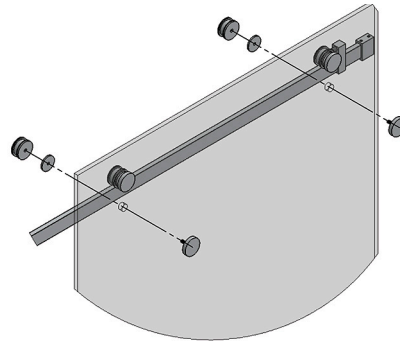
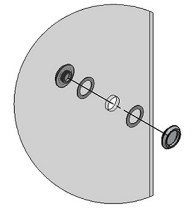
**FIGURE 15****FIGURE 16****STEP 16**

Move door to desired open/closed position, then tighten down the door stoppers to ensure glass doesn't make contact with walls. Attach any of the optional seals that are being used. Seal and tool around the perimeter of fixed panel.